

SURVIVAL GUIDE

N°15



READING IT. READING IT AGAIN. RECOMMENDING IT TO YOUR FRIENDS. RE-READING IT A THIRD TIME WHATEVER YOU DO - REMEMBER TO READ IT!



D O N O T D I E

NOWHERE 2019

NOWHERE IST, WAS WIR DARAUS MACHEN!

EXCLUSIVE!

HOW TO SURVIVE ON SITE?
HOW TO THRIVE AT NOWHERE?

JUEGOS EN EL INTERIOR



QUIZZ
WHAT IS YOUR PERFECT SHIFT?

FAIT AVEC AMOUR EN MAI 2019

WHAT IS THIS BOOK?

This is your Nowhere Survival Guide. It's a guide packed with important information about what to expect, what you'll need to get the most out of the experience and, of course, how to actually get to Nowhere.

We recommend printing this document at home before the event, and bringing it with you. If you purchased tickets for someone else, please ensure that they receive their copy of this guide, as well.

HOW DOES THIS GUIDE WORK?

You're going to see different icons alongside the pages.



This one will show you all the clickable link to Nowhere website, to give you more info.



This one is made to make you jump to a section on this guide to learn more about a specific subject.



NO-EDITORIAL

You're about to spend some time in a real desert: Nowhere happens in a really harsh environment. You need to be more prepared than you might imagine. This is part of the deal, part of the fun, and part of the experience. Let us tell you a bit about it.

After a long ride, on a road that looks like it came out of a Sergio Leone spaghetti western movie, you'll find the Nowhere entrance. Breathtaking... often, because of the extreme heat.

As you leave the vehicle, leave the idea of clean clothes behind. The dust/dirt will cover and get into everything, and we mean everything! Be a smart adventurer, be like a lizard: start by unpacking your water bottle, hat, sunglasses, and sunscreen. Head for any shade you find. Remember: you are not (in fact, nobody is) a fictional cowboy that can wander around endlessly in the arid plains of Southern Spain. So, set up camp at an APPROPRIATE time of day!!! This could be very early in the morning until 10am, or after 4pm. This means, do not try to pitch your tent at midday... why? You will end up sweating and cursing the ground, which will be too hard to drive pegs into. Trust us: you'll lose time, fluids, possibly your mind. Dehydration happens a lot faster than you think!

When setting up camp, remember to dig trenches around your tent and to firmly (VERY firmly) attach your structures to the ground. This is because... there are storms at Nowhere. Sometimes, with a LOT of rain, and STRONG winds. They'll be announced by NoMads, but make sure to take precautions... or where you live might get flooded, or worse, blown away, hurting people on its way to freedom 'à la Wizard of Oz!'

Another tip? Cover yourself with long-sleeved shirts and pants and use mosquito repellent right before sundown. This can help you avoid looking like you have a strange virus and keeping you from spending the event scratching yourself.

Still think it's fun to spend a week in the heat, among insects, and under possible massive storms? Still want to come to Nowhere?

Well, then... welcome to our Survival Guide!

Read it, follow the tips and, as many of us do, you'll have a great time, and want to come back year after year.

The No-editorial board

CONTENTS

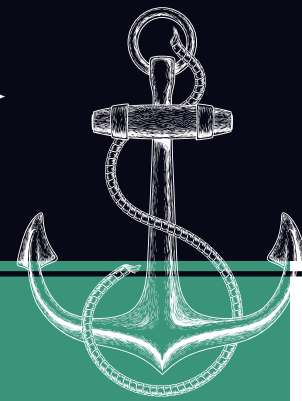

PAGES 4 TO 8

WHAT IS NOWHERE?

10 PRINCIPLES
HARSH ENVIRONMENT
WHAT WILL YOU FIND

TIMELINE PAGE 9

PAGES 10 TO 17

GET INVOLVED

VOLUNTEERING
ART
ART CARS
PERFORMANCES
WORKSHOPS & EVENT
INNOVATION PROJECTS
CREATE A BARRIO

GAME & GAME PAGE 18-19

PAGES 20 TO 23

GET PREPARED

WHAT TO BRING
WHAT YOU SHOULD
PROBABLY BRING
FORBIDDEN ITEMS
HOW TO PACK
CONTACT INFO

PAGES 24 TO 31

SURVIVING ON SITE

CAMPING
FREE CAMPING
YOU AND THE MONEGROS DESERT
How this desert will affect you...
...and how to protect yourself
LNT: how not to affect this desert

PAGES 32 TO 36

LIVING WITH OTHER NOBODIES

CONSENT
CHILDREN
EMOTIONAL SURVIVAL GUIDE
PHOTOGRAPHY
DRONES
SOUND ADVICE AND SOUND ZONES

PAGES 37 TO 41

PRACTICAL INFO

BUYING THINGS
GETTING THEREP
ARRIVAL DATE
TRANSPORTATION
DIRECTIONS
DRIVING/PARKING

PAGES 42 TO 47

SAFETY INFO

HEALTH CENTERS
FIRE AND FIRE SAFETY
EVACUATION
LAW

THIS PAGE IS FULL OF LINKS:
USE THEM TO JUMP TO SECTIONS!

WHAT IS NOWHERE?

First thing: Nowhere is a radically different experience from what you already know.

You are Nowhere. You build the barrios, the art and the art cars. You are the performer—and the audience. There is no 'them'—there is just us, and we are all in it together.

Nowhere is a Burning Man regional event in Spain, an experiment in creative freedom, participation and cash-free community.

**ALWAYS KEEP IN MIND:
YOU DON'T ATTEND NOWHERE.
YOU CREATE IT.**



10 CORE PRINCIPLES

THESE PRINCIPLES AREN'T COMMANDMENTS, AND THEY'RE NOT RULES—THEY'RE IDEALS THAT OFFER GUIDELINES TO HOW WE, AS A COMMUNITY, CAN REINVENT BOTH THE WORLD, AND OURSELVES.

SELF-EXPRESSION

THE FREEDOM TO BE YOURSELF. Be the person you are. Be the person you want to be. We respect and value you, and expect the same from you towards others. Nowhere, as a Burn, is an opportunity to live life to the fullest, in a way that could be inappropriate in the 'default world'. However, please bear your fellow participants in mind when choosing how to express yourself, freely but with respect and remember: they have rights too!

SELF-RELIANCE

YOU ARE RESPONSIBLE FOR YOU, MENTALLY AND PHYSICALLY. From food and water, to a hug or quiet space, you need to take care of yourself in Nowhere's challenging environment. Give yourself what you need—and ask others for help when you need it.

NO COMMERCE

FORGET ABOUT MONEY - THERE'S NOTHING TO BUY. By removing commerce from our community, we create cooperation and participation. We plan ahead and work together. We live without money to remind us of what's really important.

'No commerce' means there will be no money circulation at Nowhere, and, with the exception of ice, nothing to buy or to sell!

LEAVE NO TRACE

FROM DUST TO DUST, WE LEAVE ONLY FOOTPRINTS. Everything you bring to the desert has the potential to become 'MOOP (Matter Out Of Place)'. Every person is responsible for their own rubbish. We care for the environment, and we take care of our home. We clean up after ourselves, we leave nothing behind, we leave no trace after we were there.

GIFTING

WE GIVE OUR TIME, EFFORT AND GIFTS FREELY We give to help others and because it makes us feel good. From sharing a cold beer to digging out a tent pole to giving a small badge, our gifts come from our heart.

PARTICIPATION

GET INVOLVED - NOWHERE IS WHAT WE MAKE IT. The more you do, the more you get back. When you join others in play and in work, you are part of Nowhere. Your contribution is more valuable than you realise.

COOPERATION

TOGETHER WE ARE STRONGER. Co-operation is at Nowhere's core, from how we work together to how we communicate. If we can make life easier for each other, we will. If we can make life better for each other, we will. Together, we are stronger.

COMMUNITY

A FAMILY OF INDIVIDUALS, WE LOOK AFTER EACH OTHER. A diverse group of separate self-reliant beings, we are united in our need to be part of something larger than ourselves. Community, others, self—united by tolerance and joy.

INCLUSION

EVERYONE IS WELCOME TO BE NOBODY. We are grateful to everyone for their unique contribution to our community. Include others as you want to be included, with respect, consideration and benevolence. Remember, it takes more than tolerance for there to be effective integration.

IMMEDIACY

MAKE NOW COUNT. Be now here, be nowhere. Make now count. All this will soon be gone, so enjoy now. Experience, participate, be. This is all there is, so enjoy it!

HARSH ENVIRONMENT

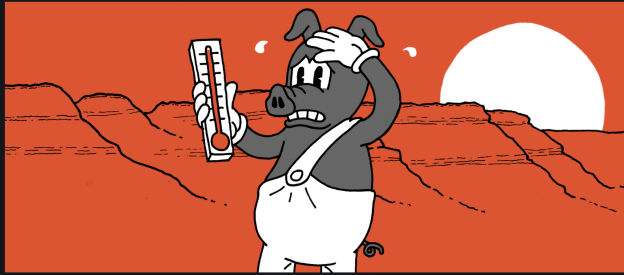

EXPECT TEMPERATURES OF WELL ABOVE 40 CELSIUS (OVER 105 FAHRENHEIT).

Nowhere takes place in the desert, in a very hot, harsh climate, with none of the amenities of modern life. Expect temperatures of well over 40 Celsius (over 105 Fahrenheit). Be prepared!

It takes time to adjust to the desert climate. Don't be surprised if you spend your first day or so feeling a bit queasy and cranky. **BEWARE:** things you can handle in the default world may hit you much harder out here! Respect the sun at Nowhere! It is not the place to work on your tan! Stay out of the sun from 1-4pm (try a siesta). Use hats, shades, sunscreens, wet clothes, and shelters to minimise your exposure.

WHAT TO EXPECT

ART

Created by Nobodies, art pieces both big and small are an important part of what makes Nowhere special. Everybody is welcome to enjoy and interact with them on the space known as 'the Field of Dirt' (formerly known as the Playa). A dedicated team will deliver different tours during the event (daytime/night time/kids-oriented) and will take you on a visit to art installations, innovation projects and maybe a ride on one of our art cars. For more details and for the departure times, check the NoInfo hub!



Nowhere doesn't want you to die. In order to do so, gentle (but tenacious) Nobodies come a month before the event and make 'friends' with nature, building nice, solid structures for us all to use!

ART CARS

You'll see slow-moving art vehicles, motorized, or not, crawling across the site. Sometimes they play music.

FIRE ARENA

Specific zone where fire artists are allowed to perform by night under supervision.

INNOVATION PROJECTS

Innovation projects are practical projects designed to make Nowhere even better!

BARRIOS

Barrios are organised camps of people who have decided to live the experience as a group. The difference between a barrio and a group of people who are free-camping together is that, as a barrio, you get placement and a mention in the event guide. However, barrios have to in turn create a public space and offer something to the event as well as some other stuff.

FIRST SHADE & WERKHAÜS

Operational spaces for the first and last crew on site. First Shade is also called "Container Village" and serve as a working space. Werkhaüs is the living space. They use it to rest, chill and play. During the event Werkhaüs is used as a normal-ish barrio that is formed by the volunteers that help make Nowhere happen.

FREE CAMP

You do not have to join a barrio. Plenty of Nobodies have a good time camping alone or with a few friends in the free camping areas. If you choose to do so, you will have to organise your own food, water, and shade. Be self-reliant!

Another big difference with the barrios is placement: you cannot reserve space in the free camp in advance, so you won't know exactly where you'll be camping until you put up your tent. The free camp is settled on a first-come, first-camped basis.

GATE & GREETERS

After the long and windy road into Nowhere, your first stop will be at Gate, home of the Grumpy Katz Gate Krew. They're happy to see you, but they're also focused on their job, which is to make sure that you have a ticket—so don't get upset if they don't give you a hug. You will need to have identification (ID card, passport) and a **PRINTED COPY OF YOUR TICKET**. Please have that ready when you arrive, especially if you are taking the bus, so that you can be processed as fast as possible, and you can get to the fun part of Nowhere!

Once you've received your entrance and wristband, the Greeters will give you the information you need to have a good burn.

MALFARE / WELFARE ENOUGH / RED CROSS

The Malfare complex (sometimes referred to as just 'Malfare') is the 24/7 operations center of the Participant Wellness department, which handles medical, welfare and safety matters. Within Malfare, there are several different services:

- * **MALFARE** coordinates safety of the participants, with the help of No-Mads volunteers, and medical assistance from professionals from the Red Cross (Real Life Spanish Pros).
- * **THE RED CROSS** can provide medical advice, medicine, stitches, IVs, and transportation (via an ambulance) to the hospital — which is 45min/1hr away. If you need to access the Red Cross, go to the Malfare tent in the complex.
- * **WELFARE ENOUGH** provides a quiet, 24-hour safe and sober space for participants to collect themselves and relax.

LA CANTINA

This is where Nowhere feeds volunteers. If you volunteer for a 6-hour event-time shift, you can eat a meal here too.

MON (MIDDLE OF NOWHERE)

Perfectly located in the (left of the) middle of the map, the Middle of Nowhere (MoN) is a large communal space. It has shade and a sound system and can be used to host workshops, performances, talks and live concerts. It's also perfect to take a nap in the hot hours of the afternoon.

OHANA HOUSE

On site, the Department of Inclusion runs Ohana House: a designated safe and sober space that welcomes people of all [insert preferred distinction]. We host daily community-inclusive events and creative activities, and offer a chill space for those seeking a place away from the thump-thumpa heartbeat of the city. This space strives to be sober and kid-friendly at all times.

TOILETS

Portable toilets, porta-potties, or plastic castles: many names for the temporary toilets you often see at festivals and other events. They are fully closed with four walls and a ceiling. These will be strategically placed (alongside some urinals) to make sure there are enough easily accessible toilets, including some wheelchair-accessible toilets.

W&R ZONE

This is the place where you can drop your day-to-day garbage. No one is paid to handle your trash, so respect the rules and keep things clean. Pro-tip: sort your rubbish before coming to the W&R zone. If you don't, you'll have to sort it there! The W&R zone is volunteer staffed, so don't hesitate to give a hand!



NOINFO / ICE ICE BABY / LOST AND FOUND:

NoInfo is a central information desk, eagerly providing advice, assistance and (drum roll) informations.

Here you can:

- * sign up for volunteer shifts (if you haven't registered on FIST)
- * announce or look for rideshares
- * find out about any last minute workshops or updates to the many daily events listed in the What? Where? When? Guide
- * send and/or deliver postcards to other humans at NoPost
- * found something not labelled? Bring it to NoInfo! Lost something valuable? Do the same.

TIMELINE

YOU WANT TO START PLANNING FOR NOWHERE?
IF YES, THERE ARE SPECIFIC TIMES TO DO THINGS.

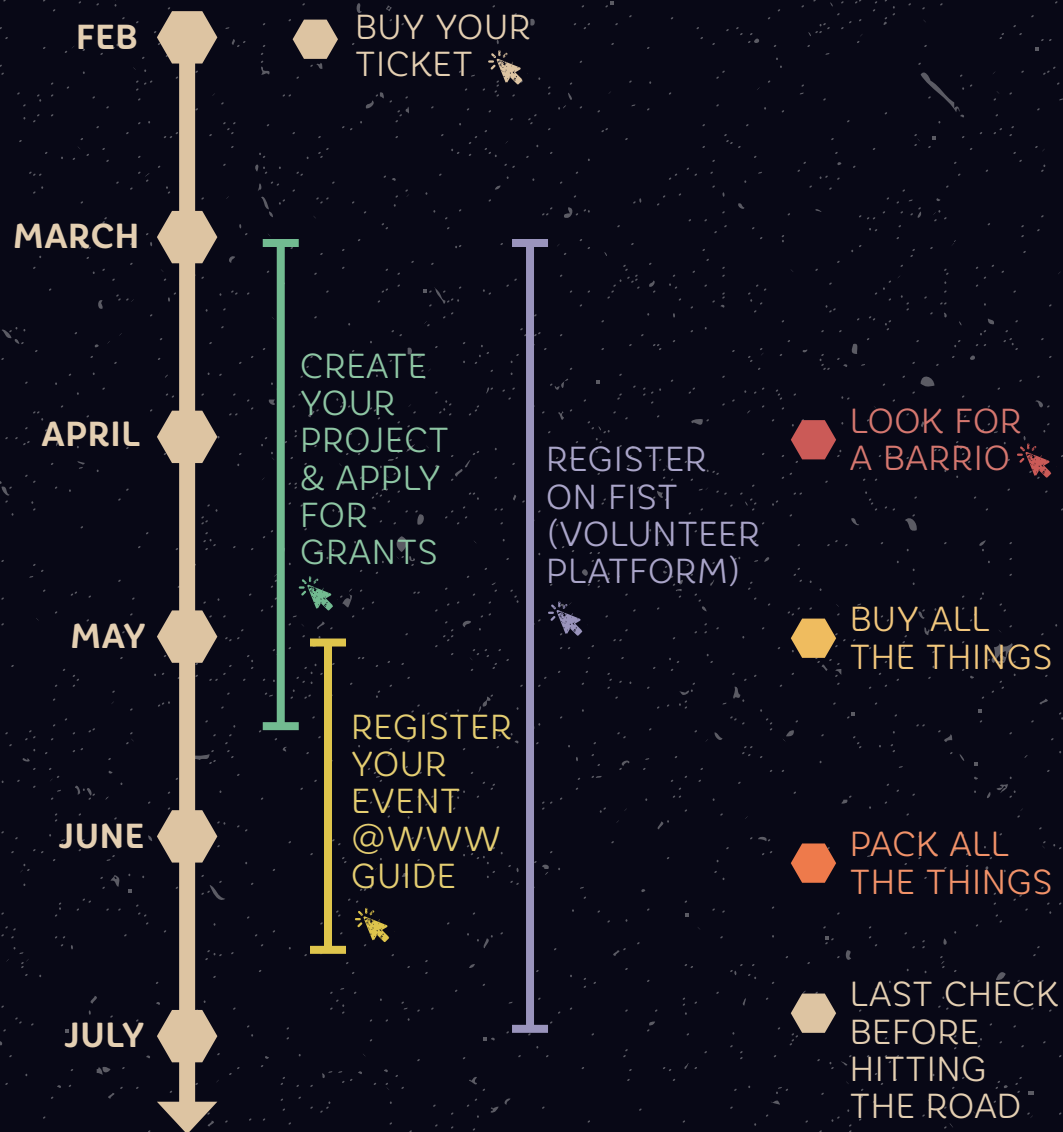



NOWHERE IS MADE BY YOU!

There are countless ways to get involved, including: arriving early for setup or staying late for strike, volunteering for a shift, making and bringing art, running a workshop, playing music, putting on a show or performance, creating and running a barrio...

BUT YOU CAN ALSO CREATE YOUR OWN WAY TO PARTICIPATE!

VOLUNTEERING

THE HERO YOU'VE ALWAYS DREAMED TO BE

Volunteering for a shift or working on a project is a great way of getting to know the community and, of course, it's awesome fun! Don't forget to register in advance.

YEAR ROUND ROLE ✨

Everything at Nowhere is run by volunteers—this means: YOU TOO! We are all responsible for what this event is. Some of us are working year round to make Nowhere happen, and you are more than welcome to join us on that journey. NOrg is the organisation that runs Nowhere, during both the event and the rest of the year. NOrg comprises Directors, Metaleads, and Leads, creating all together the backbone of the event. Want to be involved at a lead position? Take a look at the list of available roles on the website.

SET-UP (BUILD)

Set-up consists of the few weeks before the event when we raise a city from the ground up. In this short time we assemble a production office, mark the city streets, lay down the power grid, and build the essential public infrastructures. Expect harsh conditions, intense labour, and long work hours. Working set-up is extremely rewarding and a sure way to create connections strong like no other.

Coming to build?

Here is a useful checklist. ✨

FIST ✨

"For Information and Scheduling of Teams"

FIST is on our online platform where you can apply to be a volunteer. Create an account and answer some basic questions about yourself, including your emergency contact details, and then browse the roles and shifts you want to volunteer for.

STRIKE

We've had our fun, but it's also time to stick to our principles. We strike all structures, clean and chase down every last piece of MOOP until there is nothing besides a blank canvas.

This is a tough job after a week (or more) in the field of dirt but this part is crucial. "From dirt to dirt" is not only you and your tent, it's also all the structures you enjoyed during Nowhere.

If you have some extra days after Nowhere, please consider staying longer on site and help to leave no trace.



**FOR EVENT TIME SHIFT
(AKA VOLUNTEER POSITIONS)
GO NEXT PAGE**

NOWHERE CREW CONTACT NUMBER

Spanish Mobile Phone (+34) 722 221 557

If you are a volunteer pre or post event, then use this number to communicate with Nowhere. English & Spanish spoken.

GET INVOLVED

**THE GREAT
& WONDERFUL
'WHO ARE YOU?'
QUIZ**

Made to help you find Your shift(s)—yes, the one YOU were born to do. Exquisite!!!

Add one point for each sentence that suits you in each column. You "are" the letter.

1. MORE "F" OR MORE "I"?

- "F"**
- YOU ARE FULL OF ENERGY
 - TALKING IS GREAT
 - YOU SPEAK YOUR THOUGHTS OUT LOUD
 - DO FIRST, THINK AFTERWARD
 - LONELINESS SUCKS
 - YOU LIKE MEETING PEOPLE
 - TALKING INSTEAD OF WRITING
 - EASILY DISTRACTED
 - YOU CAN DO MULTIPLES THINGS AT THE SAME TIME
 - YOU ARE ABLE TO CHANGE THE WAY YOU THINK

"F" TOTAL : / 10

- "I"**
- YOU ARE A CALM INDIVIDUAL
 - YOU LIKE TO LISTEN
 - FIRST, YOU THINK
 - THEN YOU ACT
 - FEELING GOOD ABOUT YOURSELF
 - YOU LIKE KNOWING PEOPLE
 - SOME SAY YOU'RE DISCREET AND SECRET
 - DEFINITELY, YOU CAN CONCENTRATE
 - BUT ONE THING AT A TIME
 - YOU ARE INDEPENDANT

"I" TOTAL : / 10

2. MORE « C » OR MORE « U »?

- "C"**
- YOU ARE INTO FACTS, DETAILS
 - YOU LIKE USEFUL THINGS
 - YOU LIVE IN THE PRESENT TIME
 - EXPERIENCE IS THE THING
 - YOU GO DEEP INTO LEARNING STUFF
 - PROOF IS PROOF
 - STEP BY STEP IS THE REAL THING
 - YOU ARE A PRACTICAL PERSON
 - AS A PRAGMATIC TYPE OF PERSON, YOU LIKE TO CONFIRM FACTS
 - AS SUCH : WHAT EXISTS, EXISTS, PERIOD

"C" TOTAL : / 10

- "U"**
- YOU LIKE CONCEPTS
 - YOU NOTICE NEW THINGS
 - YOU THINK ABOUT FUTURE IMPLICATIONS
 - YOU FOLLOW YOUR INSTINCT
 - YOU LIKE TO LEARN NEW SKILLS
 - YOU DON'T LIKE ROUTINE
 - YOU WANT TO UNDERSTAND
 - YOU LIKE THEORY
 - YOU'RE ATTRACTED BY ORIGINAL IDEAS
 - YOU ARE IMAGINATIVE

"U" TOTAL : / 10

3. MORE « Y » OR MORE « K »?

- "Y"**
- YOU TRY TO BE OBJECTIVE WHEN MAKING A DECISION
 - YOU SEEM CALM AND QUIET
 - YOU HAVE A GOOD SENSE OF JUSTICE
 - YOU KNOW HOW TO TAKE DISTANCE
 - YOU CAN BE CRITICAL (YOU QUICKLY NOTICE FAULTS AND BREACHES)
 - YOU LOVE ARGUING FOR FUN
 - YOU ARE FRANK AND DIRECT
 - YOU ARE MOTIVATED BY NEW PROJECTS
 - YOU LIKE TO BE AN OBSERVER
 - YOU LOVE LOGIC

"Y" TOTAL : / 10

- "K"**
- YOUR DECISIONS ARE BASED ON YOUR FEELINGS AND MORALS
 - YOU ARE FRIENDLY AND SOCIABLE
 - YOU TRY TO HAVE MERCY
 - YOU TAKE THINGS TO HEART
 - YOU TRY TO PLEASE PEOPLE
 - YOU AVOID ARGUMENTS AND CONFLICTS
 - YOU CAN USE DIPLOMACY
 - YOU ARE TACTFUL
 - OTHER PEOPLE'S APPRECIATION GIVES YOU WINGS
 - YOU ARE A BIT SENSITIVE, BUT YOU CAN RELY ON YOUR FEELINGS

"K" TOTAL : / 10

4. MORE « H » OR MORE « O »?

- "H"**
- ORGANIZATION & PLANIFICATION ARE WORDS THAT YOU LIKE
 - YOU ARE A CONVENTIONAL AND SERIOUS INDIVIDUAL
 - YOU FOLLOW SCHEDULE AND ARE ON TIME
 - YOU START AND YOU FINISH
 - WORK AT FIRST AND THEN COMES THE FUN
 - YOU'RE NOT ON LAST MINUTE CALL
 - YOU DO FOLLOW THE RULES
 - YOU LIKE TO GET THINGS ON CONTROL
 - YOU APPRECIATE WELL ORGANIZED TASKS
 - UNCERTAIN, SLIPPERY OR IN THE BALANCE DON'T FIT YOU

"H" TOTAL : / 10

- "O"**
- YOU ARE A FLEXIBLE INDIVIDUAL
 - UNCONVENTIONAL AND FUN IS YOU!
 - NO TICKING CLOCKS, NO DEADLINES
 - YOU LIKE TO START BUSINESSES
 - A BIT OF FUN AT FIRST TO GET READY FOR WORK
 - COMMITMENT? WHAT?
 - YOU DO FOLLOW RULES, AS LONG AS...
 - YOU NEED TO UNDERSTAND STUFF
 - YOU WANT TO KEEP YOUR FREEDOM
 - YOU ARE OPEN MINDED, LOVE TO EXPERIMENT, ABLE TO ADAPT

"O" TOTAL : / 10

RESULTS?!

Now, combining the four letters you should have (ex. FCUH), what profile suits you the most? Within four principal groups, you could fit in:

LYNX (CH)

- FCKH** - Ohana House
- ICKH** - L.N.T.
- FCYH** - Ice Ice Baby
- ICYH** - Gate Krew

CHAMELEON (CO)

- FCKO** - Interpretor
- ICKO** - Cantina
- FCYO** - N.a.w.
- ICYO** - Perimeter

HAWK (UK)

- FUKH** - Art team
- IUKH** - Driver
- FUKO** - Nolnfo
- IUKO** - Welfare

GOLDEN RETRIEVER (UY)

- FUYH** - Malfare
- IUYH** - Slap
- FUYO** - Greeters
- IUYO** - Production

DON'T LIKE YOUR RESULT?

Don't worry, there's plenty of shifts available, and you're welcome to try any of them. Visit fist.goingnowhere.org and apply for your real role.



THE GRAVEYARD SHIFT

HERE COMES THE TOUGH CALL FOR REAL USEFUL SURVIVORS
FOR DREADFUL-BEHINDS WHO REALLY UNDERSTAND THE PRINCIPLES

When hope is gone and the Dark Skies comes along, surrounding the frightened crowd, when the Army of the Dead rises upon us, THESE are the **Mighty Heroes**, the **Only Line of Light** within desperate harsh times, THEY ARE KNOWN AS THE SHINY "GRAVEYARD SHIFTERS"
Edgar Allan Poe (veteran burner)

AS THE BURN GOES ON ...

WE CAN OBSERVE A NEGATIVE IMPACT ON REGULAR NOBODIES GOOD WILL TO SHIFT ; AS A RESULT, AN EMPTY GATE OR A LACK OF NOMADS ON INTENSE PERIOD OF TIME HAS HAPPENED, PUTTING LEADS OR EXHAUSTED VOLUNTEERS IN A REALLY UNCOMFORTABLE POSITION, PURSUING THEIR SHIFTS FOR F... HOURS.

AND IT SUCKS LET'S SAY IT.

SO PLEASE

BE DIFFERENT, FEEL CONCERNED, BE THE REAL BADASSES WHO DO STUFF, LIKE IN THE REAL SENSE OF COMMUNITY, YOU KNOW.

CAN YOU DO THAT ?

IF YOU CREATE SOMETHING FOR NOWHERE

YOU CAN APPLY FOR

CHECK OUR WEBSITE FOR MORE INFO.

A GRANT FOR UP TO 3 000€

ART

BRING US SOME ART!

Creativity and art are some of the essential elements of Nowhere. Sharing your talent and work is not only a wonderful gift but also one of our core principles.

KÜNSTHAUS

As an artist, innovator or performer, arriving at Nowhere with an already registered project or with an idea you're thinking of improvising, you need to come register with the Art Team, first. They can be found at Kunsthaus, our art hub.

Kunsthaus will give you support with a shared workshop and safe storage for your own props and tools and will be available to help with all on-site aspects of art production. It will also introduce you to the teams responsible for Performance, Innovation and Fire.

Tips: All artists need to bring their own material, tools included. We only provide some tools as backup. Metal art pieces will have to be grounded.

ART CARS

Art-pieces motorised (or not) vehicles are super fancy, but you must register them in advance by using the form on the website (ask artcars@goingnowhere.org if you can not find it) and adhering to the set guidelines you will receive.

Your vehicle must also undergo a general safety inspection on site by a member of the Art Cars Team who you can meet at Kunsthaus during daytime, before it is judged desert worthy. Don't forget: Nowhere sound policy also applies to art cars!

PERFORMANCES

OPENING CEREMONY

The Opening Ceremony is an organised procession through Nowhere with various shows and happenings planned en route, visiting many barrios and art installations, and getting all Nobodies into the spirit of Nowhere through live music and theatrical dance. If you or your group would like to be involved, please state this in your application and we will be in touch. We welcome any ideas or themes as the Opening Ceremony is a co-created event!

PERFORMERS

Smaller bands, soloists and musicians can bring their acts to Nowhere, and produce a one-off act using the Middle of Nowhere as a venue, during the event. And your performance doesn't have to stop there! Feel free to contact individual barrios for a slot, or make the desert your stage with an impromptu performance anywhere you like.

Also, small grants can be allocated for certain aspects of your work.

FIRE PERFORMERS

Do you love to play with fire? Well, lucky you! There's a fire arena where you can perform safely every night with others talented Nobodies.

The deadline for grants is **May, 15th 2019.**

If you have missed this deadline we can't fund you, but still contact us and we can help you find space to show your stuff!

INNOVATION PROJECTS

Innovation projects help to make Nowhere better in some way. Example projects might speed up the construction and takedown of Nowhere, provide better lighting, save water or electricity, provide greener power, reduce vehicle use, or find a clever way of reusing rubbish. Innovation projects don't necessarily have to be participatory or artistic, they can be 'behind the scenes' or purely functional.

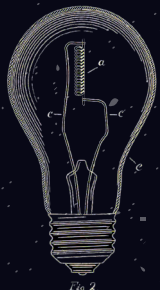

Nowhere innovation grants
DEADLINE June, 9th
check the website, we'd love to have your ideas!

WORKSHOPS & EVENTS

Want to share stuff you love to do?

Yay! Let's organize a workshop! Dance, yoga, meditation, talks, twerking...

The Middle of Nowhere is your dusty stage!

Contact us at mon@goingnowhere.org and ask if you can fit in to our busy timetable... we bet you will, and we're waiting for you!

And then, don't forget to ensure it's listed in the **What? When? Where? Guide**.
Registration will be opened in early May and workshops should be submitted before 15 June to ensure they're in the printed version.

CREATE A BARRIO

Communal camps (barrios) are a great way to pool resources. Barrios often buy communal food and water and share the costs between their members.

REMEMBER, YOU'LL NEED TO REGISTER YOUR BARRIO BY APRIL 21!

Find out about starting your own, or how to get involved with existing barrios by checking 'Barrios' on the Nowhere website.

NOWHERE BARRIO ORGANISERS FACEBOOK GROUP

Do you want to create a barrio?
If yes, read this useful separate guide:

BARRIO GUIDE

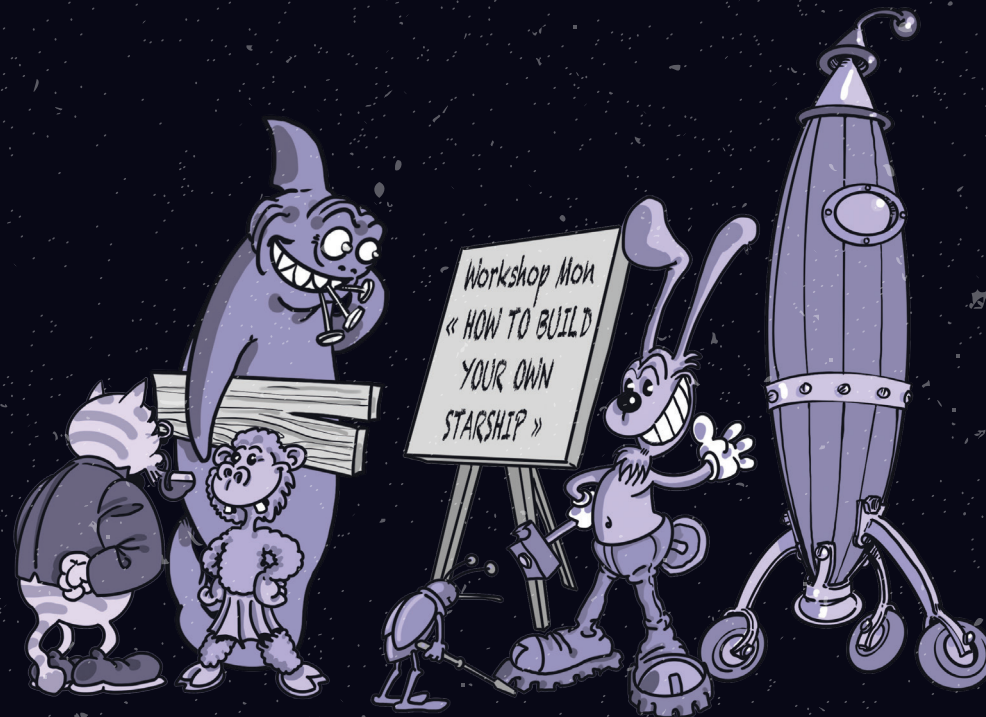

GAME & GAME

NOTHING IS SERIOUS ON THIS PAGE, EXCEPT THE FUN

CAN YOU FIND THE DIFFERENCES BETWEEN THESE TWO NOBODIES?
(SEEMS LIKE SOMEONE MISSED THE POINT!)

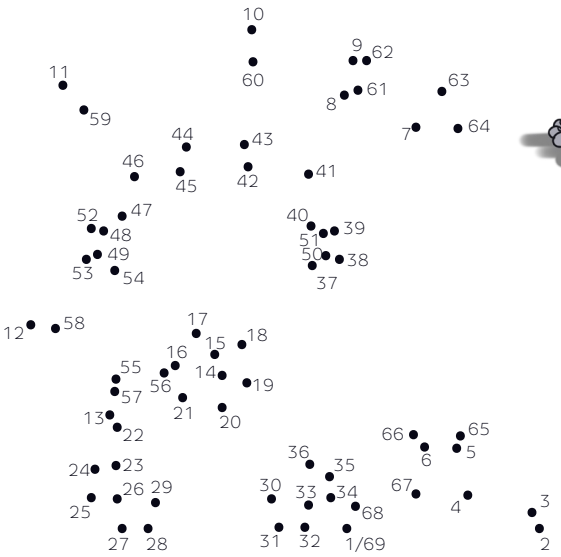

FIND OUT WHAT THE MOST USEFUL THINGS ALL THE HUMANS (EVEN THE MOST EXPERIENCED) FORGOT TO BRING TO NOWHERE EACH YEAR!

ACROSS

1. First encounter | BD**
2. I need to buy some | On your head
3. Perimeter
4. Nowhere should have more of it
5. Cannot be recovered
6. Before noon | Approximate arrival
7. Niels the atom master
9. Can be amused

DOWN

- A. Present | Spanish liquid
- B. Keep one in your sleeve | Radio
- C. Sweet home
- D. Indefinite and very long period of time
- E. Physical condition
- F. Lion scream
- G. Analysed informations
- H. Nowhere is over

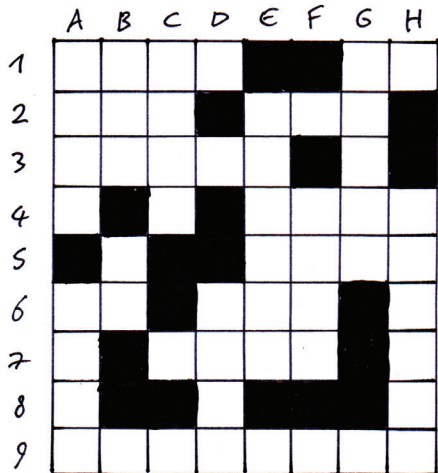

HELP THE TINY TURTLE TO FIND HER WAY TO THE HELPFUL PICKLES

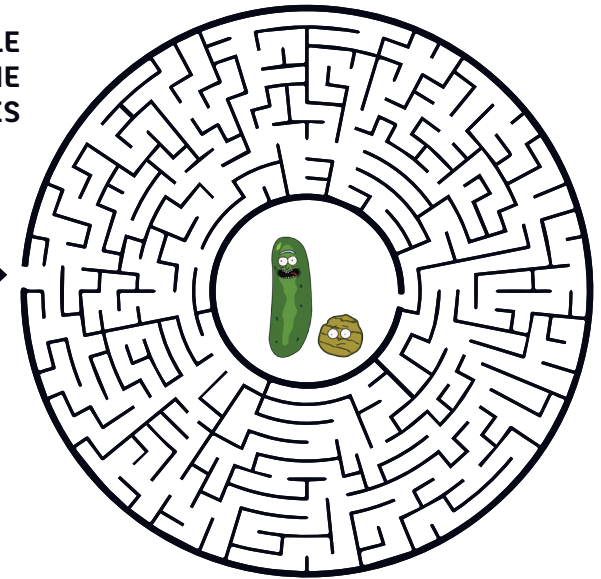

YOU WILL FIND A CLUE ON PAGE 39



15 12 15 26 26 7 25 26 8 7 10 ,
31 21 27 24 13 21 21 10 !

THERE ARE 40 (MAYBE MORE...) WORDS TO FIND! ARE YOU GOING TO FIND THEM ALL?

T	A	E	W	S	W	A	T	E	R	S	H	I	N	Y
S	U	S	T	C	N	O	I	S	S	E	R	P	X	E
C	A	W	M	O	O	N	H	M	U	L	H	V	H	I
R	S	T	A	M	P	H	S	O	R	F	E	D	U	H
E	C	R	E	M	M	O	C	O	N	R	A	U	D	M
W	Y	F	L	U	F	F	O	P	A	E	T	S	O	O
S	C	Z	W	N	H	W	O	R	K	L	N	T	O	S
P	A	R	T	I	C	I	P	A	T	I	O	N	F	K
W	I	N	D	T	O	H	E	S	H	A	R	E	O	I
E	D	A	M	Y	W	E	R	K	X	N	A	S	F	T
T	E	R	W	E	T	R	A	D	H	C	V	N	N	O
A	M	U	S	H	I	F	T	I	C	E	A	O	I	T
G	M	G	N	I	T	F	I	G	W	S	U	C	O	R
O	I	D	A	R	O	N	O	I	S	U	L	C	N	I
V	H	A	M	A	N	A	N	A	D	N	U	D	E	D



GET PREPARED

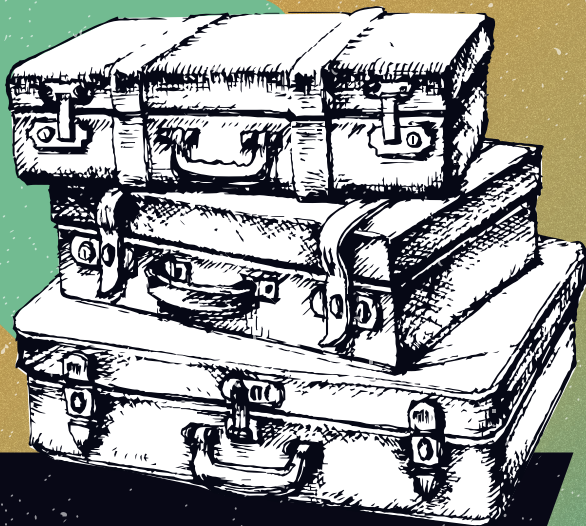

NOW THAT YOU'VE READ THE BASICS,
LET'S TALK ABOUT YOU, YOU, WHAT YOU NEED
TO KNOW, AND THE STUFF YOU NEED TO BRING.

WHAT TO BRING

DOCUMENTS

- * Your PRINTED Nowhere ticket with your name on it
- * Your ID
- * A valid European Health Insurance Card or proof of alternative Health insurance (If you're European)

CLOTHING & CO:

- * Closed toe footwear rather than flip flops for walking around
- * Clothes for BOTH very hot days and possibly freezing nights; it's a desert!
- * Goggles (for frequent, and really dusty winds)
- * Sunglasses
- * Hat, scarf, cap; anything to protect you from the sun
- * Rainwear; for a desert, it gets really muddy!
- * Towel

ACCESSORIES:

- * A torch with enough batteries and/or LED head torches (these are the best)
- * A belt or a backpack (trust us, you'll have to carry stuff ALL the time)
- * A solid cup (reusable, no glasses)

~ CUP IS MANDATORY ~

- * Water bottle
- * Sunscreen
- * Strong mosquito repellent
- * Eye wash solution, extra contact lenses, your glasses (Nowhere is very dusty!)
- * Plant sprayers/water guns to cool off when it gets really hot
- * Ear plugs and eye mask. Not everyone wants to sleep when you do!

HYGIENE:

- * Hand sanitiser
- * Eco-friendly soap
- * Any medications you may need, both prescription and non-prescription. Note: If your medications need to be kept cool, make sure to make provisions for this. Please contact malfare@goingnowhere.org for any questions or concerns
- * First aid kit
- * TRANSPARENT rubbish bags & ziplock bags or collecting MOOP and to carry your trash with you (/!\ Not easy to find in Spain)

CAMPING GEAR:

- * Tent and shade structure/awning
- * 12-inch tent stakes or rebar. It can get very windy, so your tent and any other structures you erect need to be secured.
- * Multi-season sleeping bag or an extra blanket – it can sometimes get very cold at night
- * Sleeping mat – the ground is hard and will absorb your body heat

OTHER:

- * Your kindness
- * Your positive attitude
- * Your kids (optional)

TWO IS ONE
& ONE IS NONE!

PACK * SMART



WHAT YOU SHOULD PROBABLY BRING

- * Penknife or Multitool
- * A pair of work gloves
- * Plastic bottles or tennis balls to cover dangerous rebar stakes
- * Tools to clean up after yourself such as a rake, etc.
- * Cable ties
- * Gaffer or duct tape
- * A mallet
- * A shovel
- * Portable ashtray. Don't use a beer can for an ashtray—if you do, it can't be recycled, dummy.
- * A watch
- * Tampons, sanitary towels, mooncup
- * Hairbrush
- * Lip balm/chapstick



FORBIDDEN ITEMS

- **GLASS BOTTLES** and jars
- Leave at home anything that can break up or blow away in the wind
- **FEATHERS, GLITTER:** even if it's biodegradable, it's still MOOP
- **EXCESS PACKAGING:** Remove outer layers of packaging before you get on-site. Remember: everything you bring in, you must take out again
- **EXPLOSIVES**, aerial flares, rockets, firearms of any kind, including BB guns, air rifles or paintball guns.
- **FIREWORKS**, (burning) torches, charcoal BBQs or anything else that is a fire risk. Note that gas cooking stoves and gas BBQs are allowed.
- Barbecues or other **SOLID FUEL FIRES**
- **SKY LANTERNS**, also known as Chinese lanterns
- **PETS** (only pre-registered service dogs are allowed)
- **ASTROTURF**, styrofoam coolers, plastic bags, disposable drink cups
- **LIVING PLANTS**
- **A BAD ATTITUDE**

HOW TO PACK?

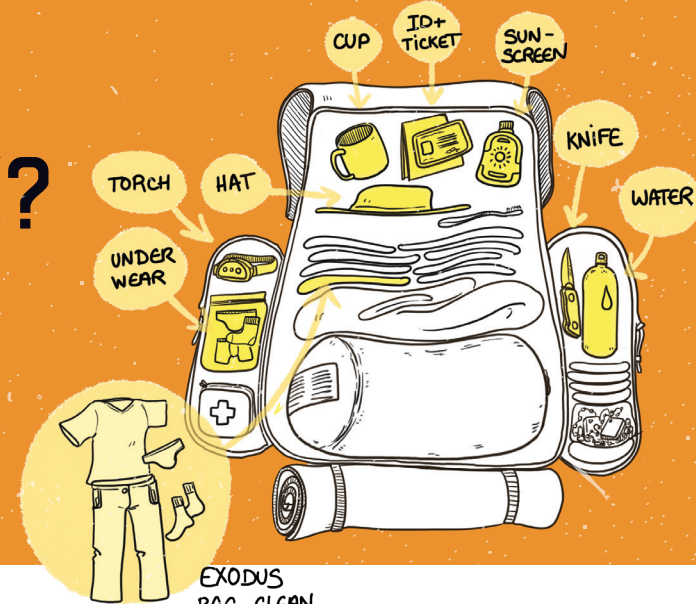

CONTACT INFO

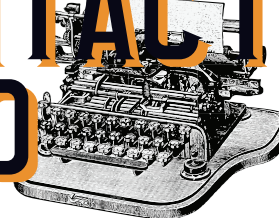

You might be unreachable at Nowhere. It is hard to find a spot to recharge your phone, and heat and phones don't mix. Cut out this card and give it to anyone that might need to reach you in an emergency. They will thank you, especially if they don't speak English. ;)



NOWHERE CONTACT INFO CARD

Number: (+34) 633 761 544
email : emergency@goingnowhere.org

Hello I am:

I need to talk to:

(playa name and/or name & last name)

because of an emergency.

They are camping at

and came with (names/playa names)

They look like

(Optional) I don't speak English or Spanish, can I have a translator?

They can contact me [phone number].....



GOOD (ENOUGH) ADVICE

SURVIVING ON SITE

~ SINCE 2004 ~

IT IS
NOT THE
PLACE

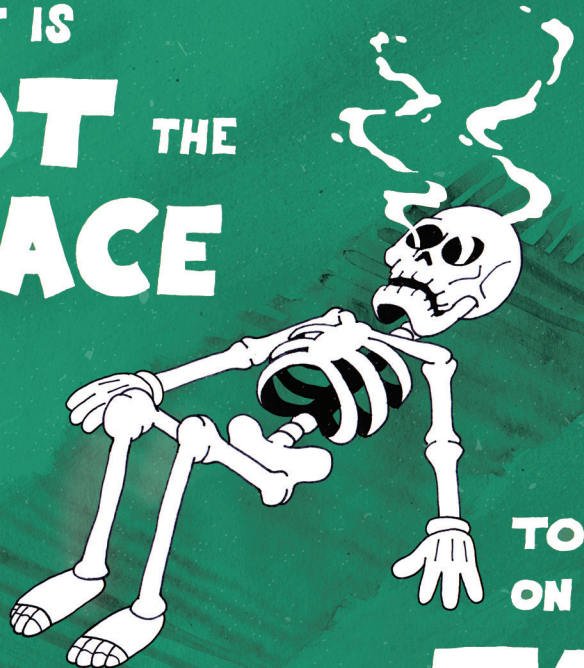

TO WORK
ON YOUR
TAN!

CAMPING (GENERAL ADVICE)

WHERE DO I PUT MY TENT?

Nowhere is divided into several sound zones (from loud to quiet).

A map of the sound zones and free camping areas will be available at the greeters station to help you choose what fits you best.

NOTES:

Freecamping areas are "first come, first served". It won't be possible to save a place before the beginning of the event.

- * The Quiet Zone has a NO vehicles, NO generators and NO amplified sound policy.
- * No camping is allowed on the perimeter road, nor outside of the camping area protected by lightning rods.
- * Stay at least 100 meters away from any flood areas. In case of rain, your tent could get washed away!



PRO TIP: PUT WEIGHT IN YOUR TENT. IF YOUR PEGS FALL OUT, YOUR TENT WON'T FLY AWAY.

FREECAMPERS

DEAR READER, WE DIDN'T CREATE A SECTION ABOUT BARRIOS. IF YOU ARE RUNNING A BARRIO OR CAMPING WITH ONE AND YOU WANT TO KNOW MORE ABOUT HOW THIS THING WORK: READ THE BARRIO GUIDE 🗺️ & HAVE A LOOK AT THE BARRIO FAQ. 🗺️

FOOD/WATER

There is no centralised water supply at Nowhere, and as you know, it is essential for your survival.

We recommend 6-8 liters per day per person. It may sound like a lot, but remember that you need it to drink, shower, cook and wash dishes.

And of course, bring enough food for your entire group for the duration of your stay. Dried, tinned and other non-perishable food is recommended. Fresh fruits and vegetables will not keep long; only bring enough for the first three days. Snacks such as nuts, dried fruit, pickles, etc. are nice and also make good gifts.

SHELTER

Please avoid cheap instant shelters that won't survive a storm. Shade material should be at least 80% UV resistant—or, even better, use two layers. Use rope or cables to tie your shelter down. 12-inch tent stakes or rebar are needed to secure your tent or other structure from strong winds.

COOKING EQUIPMENT

Bring your own cup, bowl, cutlery and washing gear. Disposable items are the biggest source of rubbish at events. Gas is the only accepted way for cooking (no charcoal or solid fuel barbecues are allowed). Make sure to be far enough from any flammable materials including tents and shelters, and ensure your equipment is in good condition.

PRO TIP: BRING SOME METAL SHEETS TO PUT AROUND THE FLAMES DURING WINDY DAYS.

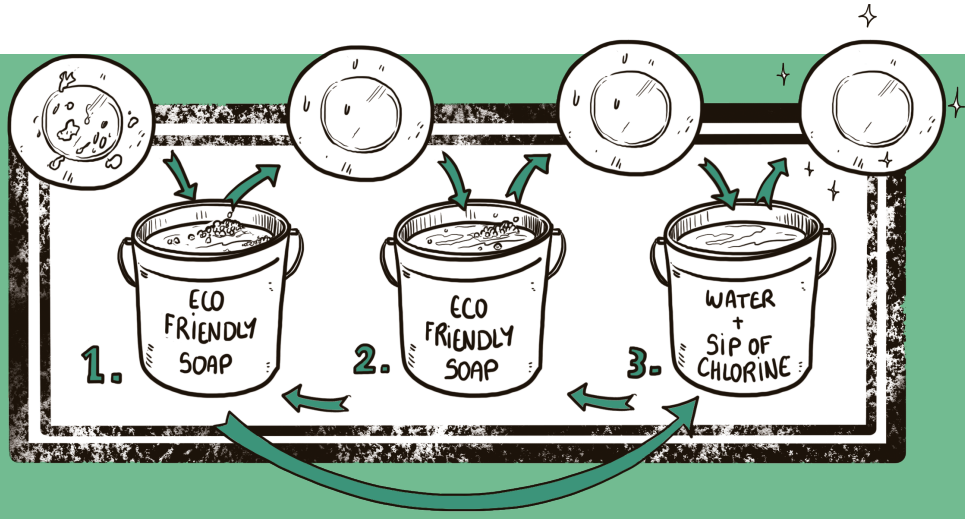

**WHEN THE FIRST BOWL IS TOO DIRTY,
RINSE IT OUT AND MOVE THE OTHER TWO BOWLS UP.
THE CLEAN BOWL CAN BE FILLED WITH WATER AND BLEACH FOR RINSING.**

HOW TO CLEAN DISHES

1. Get a bucket and three bowls.
2. Fill the first two bowls with eco-friendly soap and the last one with water and a small splash of chlorine/bleach.
3. Empty food scraps into the bucket.
4. Use the first bowl to wash any remaining food away.
5. Clean in the second.
6. Rinse in the third.
7. When the first bowl is too dirty, rinse it out and move the other two bowls up.
8. The clean bowl can be filled with water and bleach for rinsing.

SHOWER

Solar showers and pressurized camping showers are an easy and cheap way to clean up after long hot and dusty days.

GENERATOR & GAS SAFETY

(the wrong way to burn)

If you bring a generator please remember not to camp in the no-sound zone. Be sure to respect all the requirements below.

Please also consider building sound insulation around your generator. Or better still, see if you can get a group of people or barrios together to share a bigger, quieter generator.

Generators must be placed within the boundary of your camp or barrio, at least 10 meters away from the perimeter road and at least 25 meters away from any vegetation.

All generators must have a GROUNDED EARTH SPIKE, and this grounding must be certified (our team will check on your groundings with a local electrician before the governmental inspection.) Let us know if you need help with the grounding by contacting the production office before the event.

- * All gasoline tanks and gas bottles must be adequately shaded from the sun and stored far from all heat sources.
- * All rubber components (hoses, connections) must be in good condition, far away from heat sources (sun, kitchens, etc.) and protected from accidental and inappropriate manipulation.
- * Gasoline must be stored at least 15 meters away from the generator and protected from the sun and any other heat source. Moreover, big tanks must be fenced off to avoid accidental or inappropriate access.

All gasoline tanks and gas bottles must have the CE mark and be approved for use. Our technicians are required to do a daily check of all fire installations and connections to make sure they meet the permit requirements and that they will pass the Governmental inspections.

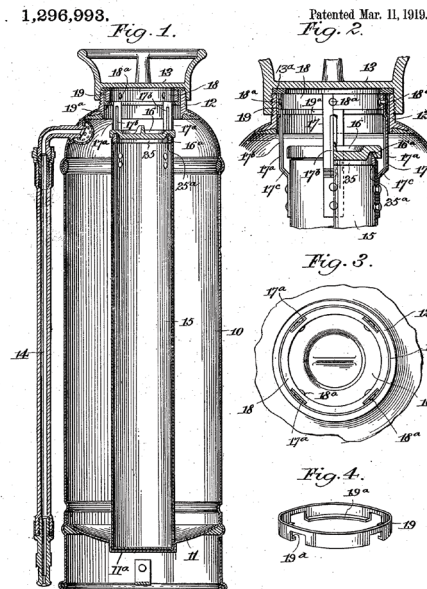

FIRE EXTINGUISHER (6KG ABC POWDER).

Even if you only have cooking equipment, it is recommended that you have a fire extinguisher around your kitchen area.

WANT TO KNOW MORE? Join the Facebook Freecamper group or email freecamp@goingnowhere.org

YOU & THE MONEGROS

DESERT UNDERSTANDING WHERE YOU ARE

HOW THE DESERT WILL AFFECT YOU...

TERRAIN

Certain areas of the site will be fenced off for your safety. Many areas surrounding the site contain holes and deep surface cracks. The hills are made of loose clay and are not suited for climbing. Anyone who leaves the site places themselves at risk of injury.

HEALTH...AND INSECTS

Believe it or not, there are insects at Nowhere. And, more importantly—they can carry disease! So, be very careful, practice good hygiene, and do what you can to NOT get sick. Viruses from the common cold, to the norovirus can spread at Nowhere.

If you exhibit symptoms such as nausea, vomiting, high fever, jaundice or malaise, you may be sick from contaminated food or water. Seek medical attention immediately and do not handle food or drink.

WIND

The wind can create beautiful dust devils, but it is powerful enough to make tents fly away and destroy structures, literally CARRYING things away with it. Remember to fix everything to the ground.

DUST

Dust goes everywhere. You will taste it, eat it and breathe it. So, remember: goggles are not just to look cool.

STORM & RAIN

Force of nature, splendid AND dangerous in a desert situation!

Remember to dig trenches around your tent and camp to avoid becoming part of a newly formed river or mudslide.

BIOHAZARD SITE

We're located in a protected "green" area, true, but areas around us are slightly different. The river nearby has chemical runoff from farming and is definitely not clean.

SYMPTOMS OF DEHYDRATION:



Headaches, stomach cramps, abdominal pains, constipation or flu-like symptoms are signs that you are dehydrated, and are both heat-related and cold-related symptoms (sunstroke and hypothermia).

If you or someone you know complains of these symptoms, or shows signs of either severe overheating, or worse, a case of chills under the midday sun, get them to shade immediately and have someone contact Malfare. Use of alcohol, caffeine and other drugs will place you particularly at risk of dehydration, and you should pay careful attention to your water intake.

SOME SIGNS THAT YOU ARE NOT DRINKING ENOUGH WATER:

- * You don't carry a water bottle with you at all times
- * You swill or sip instead of drinking deeply
- * You wait to drink until you're thirsty, which is too late
- * You become cranky
- * Your urine is anything but clear and abundant

SUN/HEAT

It's really hot around here. Respect the sun. Stay out of the sun from 1-4pm (try a siesta). Use hats, sunglasses, sunscreen, wet clothes and shelter to minimise your exposure.

REMEMBER TO 'PISS CLEAR'.

Clear urine is the best sign that you are hydrated. Drink water or rehydration fluid all the time, even if you are not thirsty. Make sure you have enough salts and minerals: drinking water is not enough.

ALSO REMEMBER: THERE ARE THINGS YOU CAN HANDLE IN THE DEFAULT WORLD, THAT WILL BE MUCH HARDER TO LIVE WITH AT NOWHERE!

...AND HOW TO PROTECT YOURSELF!

CARRY WITH YOU

This is a list of things you should carry with you all the time:

- * A torch with enough batteries
- * A belt or a backpack
- * A cup made of aluminium or plastic, with a carabiner
- * Water bottle
- * Goggles (really dusty winds are frequent)
- * Sunglasses
- * Hat, scarf, cap, anything to protect you from the sun
- * Sunscreen
- * Mosquito repellent—a strong one
- * Hand sanitizer
- * Rubbish bag & portable ashtray

REHYDRATION FLUID RECIPE

Per 10 litres:

- * 26g of salt (for sodium)
- * 29g of carbonate of soda
- * 15g of potassium chloride (aka low sodium salt)
- * 5L of juice (avoid grapefruit)
- * 1,5L of sparkling water
- * 1 bag of Ice (2L)
- * 1,5L of water

Mix all this together well and rehydrate. Alternatively, bring a good supply of your favourite sports/recovery drink or electrolytes/rehydration sachets from the chemist.

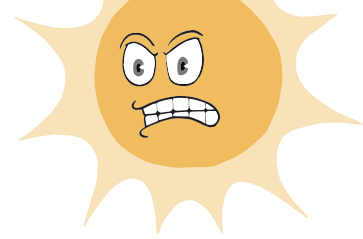

WASH YOUR HANDS

RULES OF SURVIVAL: WASH YOUR HANDS FREQUENTLY (after using the toilets, before preparing, cooking or consuming food; after a group activity where contact was made). Also bring hand sanitiser and use it often.

NOT A RUNNING GAG but a serious way to avoid trouble.



HAVE YOU WASHED YOUR HANDS?

LEAVE NO TRACE: HOW NOT TO AFFECT THIS DESERT

Essentially, you take responsibility for your environmental impact. Remember, there must be no evidence you were ever at Nowhere. THIS IS YOUR EVENT. BE KIND TO IT AND IT WILL BE KIND TO YOU.

HERE ARE THE RULES TO REDUCE YOUR IMPACT AT THE EVENT:

- * Prior to departure, **remove all surplus packaging** to minimize waste generation.
- * Be careful with **MOOP** (Matter Out Of Place): everything which doesn't belong to nature shouldn't be on the ground. Please be extra careful and pick up MOOP if you see some.
- * Use **transparent rubbish bags** helps ensure the correct sorting of rubbish and the safety of volunteers handling it.
- * **Every day rubbish needs to be cleared from the area where you are camping and/or your barrio.** Rubbish should be taken out to the W&R Zone during opening hours. Check the WWW Guide What? Where? When? Guide! for the location and opening times of the W&R Zone.
- * **If you are going into town for shopping** take your sorted rubbish to one of the recycling containers there to reduce garbage accumulation on site.
- * **Take your stuff back home.** If you were able to bring it, you'll be able to take it back (and Nowhere doesn't have to take care of it for you (volunteers, community, etc.)
- * Remember to leave enough time to help pack & clean up and ensure you **LEAVE NO TRACE.**
- * Before leaving, do a sweep of your tent area.

HOW TO USE THE W&R ZONE PROPERLY

W&R Zone is the designated site for rubbish and recycling to be taken to not far from the main Nowhere site.

This is to be used with care and respect, always remember that volunteers don't have to deal with the stuff you don't want to.

Trash in the W&R Zone must be separated into the following categories:

- YELLOW:** Metal, Plastic & Tetrapacks
- GREEN BELL SHAPED:** Glass, bottles and jars
- BLUE:** Clean Paper and Cardboard
- GREEN cube bin Garbage:** General Waste (keep minimal!)
- COMPOST HOLES:** Compost & Dirty Paper / Cardboard (e.g., paper towels, coffee filters) No meat, dairy, or citrus



If you don't sort your trash properly, you'll have to do it again, and you don't want to put your hands in the trash bag again. Plan ahead!

GREY WATER

Grey water (waste water) must NOT be thrown into the toilets or added into compostable material as this contains harmful chemicals which upsets the balance of the composting. To deal with your grey water, please only use eco-friendly/biodegradable soaps, detergents, shower gels, etc. Then, filter or sieve all water to remove large elements such as food waste, etc. These are to be added to your general waste. Finally, either collect your grey water to be disposed of in the local town, create an evaporation pond or evaporation delta, or spread it in the surrounding bushes.

Remember that earth at Nowhere is not very porous.

DO NOT DIG DEEP PONDS AS THE WATER WILL NOT SOAK AWAY AND IT WILL ATTRACT FLIES AND MOSQUITOES.

HOW TO USE THE TOILETS 🌿

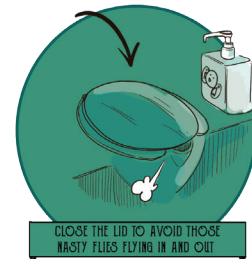
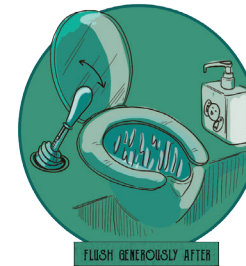

There are some key differences compared to domestic toilets. Only the 3 Ps should go in any toilet: Pee, Poop, Paper. NO wet wipes, tampons, plastic or any other objects please.

Each portalo is regularly stocked with toilet paper and hand sanitiser.

Toilets are looked after by an army of awesome 'SHIT Ninjas.' Each barrio has one, and their name will be posted by each toilet.

If there is a problem with a toilet (lack of paper/hand sanitiser, etc.), please let them know so that the problem can be fixed ASAP and to everyone's benefit.

Human faeces are toxic and can cause serious illness. Please don't poop anywhere other than the toilets provided!

LIVING WITH

SINCE
2004



OTHER NOBODIES

We have a **Department of Inclusion**.
It works to ensure that all language groups, age demographics, and minority groups among the community are considered and supported in the planning and completion of the event.
For more information, visit the website www.goingnowhere.org or email inclusion@goingnowhere.org

CONSENT

NOWHERE CAN BE AN EROTICALLY CHARGED ENVIRONMENT. WE WANT TO HELP PREVENT SEXUAL HARASSMENT AND ASSAULT WHILE ENSURING THAT SEX-POSITIVE FREE EXPRESSION THRIVES! IT IS IMPERATIVE TO KNOW AND EXPRESS YOUR OWN SEXUAL BOUNDARIES, AS WELL AS TO ASK ABOUT AND RESPECT YOUR PARTNERS' BOUNDARIES.

SILENCE IS NOT CONSENT!

Communication is the best lubricant: always ask and wait for a 'Yes!' Anything which is not an enthusiastic 'Yes' has to be understood as a 'No,' and respected with a smile.

Consent is sometimes called the 11th Principle. It's something that we all like to think we understand, or that we're only ever respectful in our interactions with other burners. Unfortunately, consent violations happen at burns, too. They can ruin someone's experience—or worse.

Consent is a framework we can all use to ensure no one is subject to the unwanted actions of others. Consent isn't just about sex, it is needed before acting on any desire involving others, including non-sexual touching, using other people's belongings, and taking photographs. So... how does one become a highly consensual person? Here's a step-by-step guide.

1. KNOW THE DIFFERENCE BETWEEN WHAT IS YOURS AND WHAT BELONGS TO OTHERS.

It seems straightforward: my body is mine, and your body is yours. But have you ever had the impulse to pinch a baby's chubby cheeks, or smack a friend's bum? You saw it, it looks irresistible, it's right there...so you can touch it, right? No, you can't! Getting consent is the key.

2. ASK FOR WHAT YOU WANT FROM A PERSON WHO IS ABLE TO CONSENT.

In order to legally consent regarding sex, one must be of a legal age to consent and physically able to consent (not unconscious, sleeping, or too intoxicated). The last one can be tricky, so it is generally better to wait until everyone involved is pretty sober. Next, you need to ask for what you want. This can be scary, because you might hear 'No' and feel rejected or embarrassed. But this gets easier with practice.

Voyeurism is participation:

Ask before engaging in sexual activity while in clear view of other people. If people around you don't want to participate, find a better location. Barrios must clearly mark spaces where sexual

activity or adult-oriented events will happen, and must indicate that minors cannot enter. Minors will have a different color wristband than general participants.

3. LISTEN TO THE ANSWER.

After you've asked for what you want, you need to wait to hear a response. Remember: silence is not consent. If the person doesn't respond, wait until you hear an answer. Let the other person know that you won't proceed unless they say 'Yes.' If they answer 'No,' accept this. Do not try to talk them out of it, or persuade them to change their answer. 'No' is the answer.

4. SHOW GRATITUDE FOR ANY ANSWER BUT ESPECIALLY "NO".

A true master of consent not only accepts the answer, but shows gratitude for it. It is easy to show gratitude for affirmative answers, but it's even more important—and harder—when someone says 'No.' Saying no can be hard... People often fear being seen as uncool for saying no. We must remember that saying 'No' is part of Radical Self-Expression!

5. KEEP CHECKING IN. Even after being told 'Yes,' keep checking in. Check to make sure each new action is ok before going forward. Be aware of a partner who goes still or silent; check in and make sure they still consent. Some people may do this when they are scared or feel traumatised. Although you may have done nothing wrong, the person you're with may suddenly feel unsafe for some reason. Check in, stop what you are doing, and wait for your partner to verbally confirm that they still consent.

6. STAND UP FOR CONSENT. Lastly, as masters of consent, we should always be aware of those around us. We are often confronted with situations that seem questionable. You can and should check in on others, even strangers. Do you feel safe? Are you okay? Do you need to find a safe place or friend? Is everyone here fully consenting? These are all good questions to ask in uncomfortable situations. Be willing to help a person in a non-consensual situation get to safety, whether it is to Malfare or to their friends.

WHERE TO GET HELP

- * **Find a Nomad** or go to the Malfare tent if you feel you are in immediate danger.
- * **Report incidents to Malfare** or use the anonymous reporting box in the Welfare Enough dome.
- * **Talk to someone in the Safe Space** by using the anonymous reporting box in Welfare Enough to request it. The box is checked at 16:00 each day Tuesday-Saturday and at 11:00 on Sunday. We will do our best to find someone of your preferred gender and language amongst our team of listeners to meet you at the Welfare dome the same day an hour after the box is checked (17:00 Tuesday-Saturday, 12:00 Sunday) to welcome you into the Safe Space for a chat. The person will wear a blue hat to identify themselves.
- * **Email consent@goingnowhere.org** to report an incident after the event is over.

CHILDREN

From the standpoint of Nowhere and the law, a child is anyone under 18.

Check with the barrios for their opening hours to minors and the WWW guide for family-friendly workshops. Beyond this, Nowhere does not dictate what is appropriate for your kids; as their parent/carer, you do. Remember kids can be more affected by the harsh environment than us grown ups!

Lost under-12-year-olds will be taken to Malfare until the adult caring for them is found.

Looking for a place to go? Ohana House serves as a hub for families. It hosts an annual discussion session about bringing children to Nowhere, which is open to anyone.

REMEMBER THAT

- 1. IF YOU ARE RUNNING A BAR:** serving alcoholic drinks to minors is illegal. They will have a different coloured wristband to be recognized.
- 2. SEXUAL ACTS IN PUBLIC:** Engaging in sexual acts in a place where minors could be present is a major crime in Spain. If you choose to engage in sexual activities at Nowhere, do so in private or in adult-only spaces.

EMOTIONAL SURVIVAL GUIDE PHOTOGRAPHY

Everything is tougher at Nowhere. This also goes the way you handle things—it can be more difficult, there! For example, interacting might feel too intense at times, and/or you may feel a bit alone or alienated, without familiar comforts to rely on. But there are plenty of ways to deal with this!

HERE ARE SOME TIPS :

- * Be gentle with your body
- * Seek help if you need it
- * State your boundaries and communicate—whether with strangers or your loved ones
- * Have the experience that makes YOU happy
- * Connect in ways that make YOU comfortable
- * After Nowhere, be smart, and take time reflect on your choices—be it at the event or in the 'default world'

Don't forget to read the Nowhere Emotional Survival Guide 

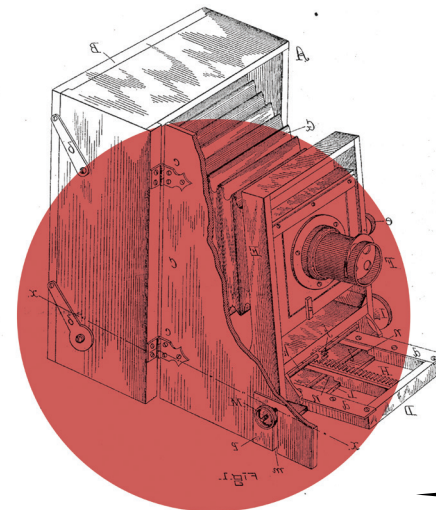

Nowhere is a special place, where people are encouraged to express themselves in a variety of colourful ways. It is a ready feast for the eyes, and the camera.

ALWAYS ASK PERMISSION. DO NOT TAKE SOMEONE'S PHOTO AGAINST THEIR WILL.

- * In the event that you have a dispute with someone about photography, please flag down a NoMad or come to Malfare, so that the volunteers there can help to mediate the situation.
- * Your right to take someone's photo and publish it NEVER over-rides their right to privacy!
- * If you're posting photos on Facebook or other social networking platforms, MAKE 100% SURE that EVERYONE featured in your photos is happy for them to be posted, BEFORE they go online. You should not be tagging people online unless you have their explicit permission.
- * NO photos should be taken and published for COMMERCIAL use without the written permission of the Nowhere Organisation.
- * Private camps are sacred ground: do NOT enter someone else's camp and take photographs!
- * Anyone recording video must follow the same rules.
- * We do have some approved journalists onsite—their cameras will be marked with a tag saying 'Media,' and you can ask them not to photograph or film you.

DRONES

In order to respect privacy and boundaries, unauthorized drone flight isn't permitted on site during the event. Although Nowhere, its surroundings, and its Nobodies are indeed beautiful and photogenic, just like with pictures, it's essential to get permission before taking any footage of someone. Unfortunately, with drones it's impossible to do so.

You can fly your drone OFFSITE, but you absolutely must stay 50 m horizontal from the site perimeter. Specific flights can be permitted only if okayed by the Comms team beforehand, and then, may be carried out under supervision. Or else...unauthorized flights will probably be shot down with a giant slingshot. Email comms@goingnowhere.org for more info.

SOUND ADVICES & SOUND ZONES



Nowhere is a 24-hour experience, held on a small site. Not everyone will be sleeping or dancing when you are. For this reason, it's important that you control how far your sound travels across Nowhere. We ask that you respect the sound zones and pre-register with barrios@goingnowhere.org so we can make sure your barrio is in the right zone.

If you would like more advice on how to control sound at Nowhere, visit the sound FAQ [or](#) contact the sound team at sound@goingnowhere.org.

PRACTICAL INFO



FIG. 123

THE SOUND POLICY

	RED ZONE	ORANGE ZONE	YELLOW ZONE	GREEN ZONE	BLUE ZONE
	For about 100m around the edge of these camps, art cars are allowed to drive and play music with similar sound systems.	For about 50m around the edge of these camps, art cars are allowed to drive and play music with similar sound systems.	For about 50m around the edge of these camps and all places where art cars are allowed to drive.	No loud speakers, only background music (during the day) and generators sounds.	No noise above conversation level, no generators, no cars and no sound systems of any kind at any time.
SUNRISE TO 11 AM	AFTER 7 AM				
11 AM TO SUNSET	DISCOTHÈQUE LEVEL	BAR LEVEL	LIVING ROOM PARTY LEVEL	LIVING ROOM PARTY LEVEL	CONVERSATION LEVEL
SUNSET TO 4 AM	DISCOTHÈQUE LEVEL	BAR LEVEL UNTIL 3 AM	LIVING ROOM PARTY LEVEL	CONVERSATION LEVEL	
4 AM TO SUNRISE	LIVING ROOM PARTY LEVEL	LIVING ROOM PARTY LEVEL	CONVERSATION LEVEL		

BUYING THINGS

WHAT YOU CAN BUY LOCALLY

The local communities have been very supportive of Nowhere, so consider supporting local businesses by shopping for supplies in the nearby towns of Castejón de Monegros, Albalatillo or Sariñena, en route to the site. Please remember to dress for civilization when you go into town!

Castejón de Monegros is the closest small town to the site, but it's harder to reach due to poor road conditions. It has:

- * A general store (basic food, water, etc.)
- * A bakery
- * A butcher
- * A petrol station (that also sells ice)

Sariñena is slightly bigger than Castejón and has a wider choice of shops and other facilities. It has:

- * Cash machines (ATMs)
- * Larger supermarkets
- * A hardware store (Ferreteria) – Salamero (Av Huesca, 25. 22200 – phone number +34 974 26 50 35, Sia (Barrio Estación, 78, 22200 Barrio de la Estación, Huesca Tel: +34 974 57 07 77 Opening hours 08:30 to 13:30 and 15:30 to 19:30.)
- * A pharmacy (Farmacia)
- * The nearest health centre (see below for address)
- * Two hotels
- * A railway station (though this is about 3 km away from the actual town)

GAS: BE CAREFUL! SPAIN HAS ITS OWN SYSTEM

- * Most hardware shops or the plumbing department of big DIY shops like Leroy Merlin sell small camping gas containers.
- * 6kg butane (butano) bottles can be purchased in Repsol, Campsa, and Petronor service stations, including the one in Sariñena. You need to leave a deposit for the purchase, and then return it. There are not many available in town.
- * You need to sign a contract to buy larger (12.5kg) bottles, and pay a deposit on the bottle.
- * Propane (propano) is not easy to buy. Some shops may insist that you have an empty gas bottle to exchange for the new one.
- * Spanish gas bottles have a specific bayonet connector that isn't compatible with other systems, so ensure that you have the correct connector on your gas appliance if you are buying gas in Spain.
- * Some hardware stores sell converters to enable you to connect standard European camping gas appliances to Spanish gas bottles.



WHERE ELSE TO SHOP AROUND

Huesca and Zaragoza (Zaragoza is further away), and the regional commercial centre, they have:

- * Cash & carry—Makro (cardholders only)
- * Supermarkets—e.g., Carrefour
- * DIY, wood yard—Leroy Merlin, Brico Depot, Aki
- * General hardware supplies ('ferreterias')
- * Car/van/power tools rental
- * For groceries, Fraga or Lleida are also worth a look if you're heading in from Barcelona or from the north of Spain.

SPANISH SCHEDULES

ALMOST NOTHING IS OPEN ON SUNDAYS.

Consider this if you're planning on getting supplies before arriving at Nowhere. Only big malls and supermarket chains open the first Sunday of each month, but just in in Zaragoza and Huesca.

OPENING HOURS:

Small shops: from 9:30 am to 1.30 pm, and 5pm to 8pm.
Closed Saturday afternoon and Sundays.

Supermarkets: from 9:00 am to 9.00 pm. From Monday to Saturday included.

Out of town supermarkets such as Carrefour are generally open 10am to 10pm six days a week.



GETTING THERE



ARRIVAL DATE

GATE OPENING: MIDDAY - MONDAY 8 JULY.

Ticket-holders will be allowed on-site to set up their camps and help other projects before the festivities commence, with a prearranged valid Early Entrance. Don't come earlier than midday...or you'll have to wait under the sun.

Nowhere starts: Tuesday 9 July 2019.

EARLY ENTRY: WEDNESDAY 3 JULY

Only pre-registered volunteers, barrios and those who have previously discussed their projects with arts@goingnowhere.org, volunteers@goingnowhere.org or barrios@goingnowhere.org will be allowed on-site earlier than MIDDAY Monday 8 July.

IF YOU TURN UP AT THE GATE BEFORE THIS YOU WILL BE TURNED AWAY!

TRANSPORTATION

PLANE

The closest airports are: Zaragoza, Barcelona, and Reus. It can also be useful to check out flights to Girona, Bilbao, Madrid, and Valencia.

TRAIN

The nearest railway station and bus stop is Sariñena. Please bear in mind that the railway station is about 3 km away from the town. Details of public bus and train services can be found here

TAXIS

There is a taxi service from Sariñena to Nowhere and vice versa. Just call:

* Yoli Sales: +34 615 974 052

* Amadeo Sales: +34 619 726 466, +34 974 570 138, +34 615 323632 Taxis are 4 and 8 spaces. Flat rate; €45 from Sariñena train station, €40 from Sariñena town.

NOWHERE BUS

Our amazing bus crew has organised a few buses from Barcelona and Zaragoza to the land of dust.

To see the schedule and purchase tickets, go to the Nowhere Bus Tickets page or join the **Facebook group**. For any questions about the bus, email bus@goingnowhere.org.

SHARED CARS/RENTING CARS

Carpooling is a cool way for getting to Nowhere with friends, or for making new friends. You will also help to reduce traffic and air pollution. Ride sharing is also a great way to share on travel costs too. For more information please check:

PERSONAL VEHICLE

Of course you can use your own vehicle to come at Nowhere.

DIRECTIONS

Nowhere 2019 is at:

GPS: 41°40'45.4» North 0°09'04.3» West
(or 41.679270, -0.151182 if you prefer.)

Start with the REPSOL gas station (Avenida de Fraga, 17, Sariñena) on your left and head out of Sariñena (put km at 0)

After 400 meters, pass on the bridge and go right

At km 7.4 turn right (there's a big brown sign that reads RUTA JUBIERRE)

At km 11 the road forks, keep to your left

At km 12.2 the road forks again, keep to your right

At km 13.3 cross the bridge

At km 13.9 the road takes a 90 degree angle (there's a COTO DEPORTIVO DE CAZA sign), follow the road up towards the Ermita (small church you'll see after a few metres on your left)

At km 14, pass the Ermita on your left and keep going straight

At km 14.6 you'll find the fork to go to the 2013 Nowhere site, **DON'T TURN, KEEP GOING STRAIGHT**

At km 15.1 you will pass the turning to the right to the 2016 Nowhere site. Again **DON'T TURN, KEEP GOING STRAIGHT**

At 17.1 turn left onto the road to Nowhere...

At 19.5 you will reach Gate. **WELCOME HOME!**

DRIVING/PARKING

Nowhere is a traffic free event, except for Art Cars on specific terms.

When you arrive on site, you'll have 2 options:

1. If you need to use your vehicle during the week, for example to go to town for groceries, you'll need to park in the parking lot. You'll be able to unload your vehicle in your camping area before parking, but you may not drive back into the event once the vehicle is parked.
2. If you need/want to have your vehicle around your camping area/barrio, you'll need to get a permit at Gate and place it behind your windshield. Please remember that **IF YOU PARK ON-SITE, YOU CAN'T MOVE YOUR VEHICLE UNTIL THE END OF YOUR STAY.**

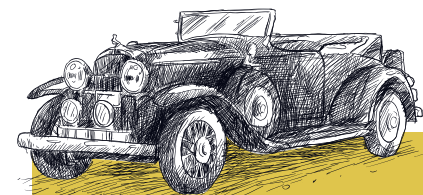

GENERAL RULES

Respect the 10 km/h speed limit

Only use the perimeter roads

No cars allowed to drive on site between Sundown (approx. 9 pm) and Sunrise (approx. 7 am)

If you arrive at the gate after Sundown, you will have to park your vehicle in the parking lot and get it back the next morning.

SAFETY INFO

**DIAL 112 FOR ALL
NATIONAL EMERGENCY
SERVICES.**



HEALTH CENTERS

For emergencies, there are health centers (Centros de Salud) in:

SARIÑENA: 25 minutes away. Address: Carretera Zaragoza. Avenida Zaragoza, 10, 22200, Sarinena. Phone number: +34 974 571 027 (emergencies) or +34 974 571 202 (bookings)

HUESCA (HOSPITAL): over 1 hour away. Address: Hospital San Jorge. Avenida Martínez de Velasco, 36, 22004 Huesca. Phone number: +34 974 247 000

SAFETY FIRST!

Health centres will treat anyone for free, but you will pay for any medication at the pharmacy. If a hospital visit is required, you will have to pay if you don't have a **European Health Insurance Card.**

FIRE & FIRE SAFETY

If you have fire puffers or other sort of effects in your camp/art piece, please contact us before the event at firesafety@goingnowhere.org.

There is an extreme risk of wildfire in Los Monegros and there is a TOTAL ban on fire in this area. This is enforced by law.

THIS MEANS:

- No fireworks, fire torches, or firecrackers.
- Do not flick away cigarette butts!
- Do not light barbecues, campfires or other fires (gas barbecues and gas camping stoves are okay, solid fuel of any kind is not).
- No kitchen or source of heat can be placed within the first 10 meters inside the perimeter.
- No playing with fire toys outside of the designated area (Fire Arena) and times.

PLEASE READ CAREFULLY THE INSTRUCTIONS NEXT PAGE... IN CASE OF EMERGENCY, YOU WILL THANK YOURSELF FOR HAVING DONE SO!

In case of fire, a perimeter will be established to protect people, and this perimeter will be grown as needed up to and including a full site evacuation.

Any fuel filled item (gas bottles, gasoline) should be moved away/out of the path of a potential fire including moving vehicles and potentially flammable/combustible objects out of the way but do not in any circumstances obstruct—even temporarily—the access roads and especially don't put yourself in danger!

**PLEASE ALWAYS FOLLOW THE INSTRUCTIONS.
DON'T BE A HERO, DON'T BECOME PART OF THE PROBLEM!**

IF YOU SPOT A FIRE:

- * Call for help, and ensure that people understand your need
- * Move people away from the fire
- * Move anything flammable (wood, tents, gasoline) away as much as you can
- * Fight the fire up to your level of comfort
 - * Expend no less than 2 extinguishers to combat the fire
 - * Use dirt or water to continue to put out the fire

In every case, Nowhere Site Lead will call the local fire department.

EMERGENCY 112

FIRE ALARM

There are two fire event types which would cause a rapid evacuation of the site.

- If there is a fire onsite
- If there is a fire if offsite—and if it threatens the event and its participants

If Norg personnel (Malfare and Emergency Teams) think the fire cannot be contained, then a site evacuation will be performed. The Malfare Shift Lead will be in charge of evacuation and may deviate from the protocol as the event unfolds.

Please follow the instructions of people wearing high visibility vests and help them gather all your campmates. When the shit hits the fan the life of everyone depends on everyone!

WHEN YOU HEAR THE AIR-SIREN ALARM, GO QUICKLY TO THE MEETING POINT (in front of Red Cross) LEAVING YOUR BELONGINGS BEHIND. BE READY TO WALK TO THE EVACUATION POINT (Ermita de San Miguel, unless differently instructed by Malfare personnel.)

EVACUATION

Due to the size of event, Nowhere is required to have an approved evacuation plan in place and a means of communicating it to all attendees. **When you arrive you must check our emergency plan at the Gate** with information about the safety & emergency procedures. We ask that you read this and discuss it with your campmates, people camping near you, and complete strangers (we call them New Friends).

SITE EVACUATION

All people on site MUST evacuate as directed by the Malfare Shift Lead and Malfare personnel (in high visibility vests), via the designated routes.

- DISABLED PEOPLE shall be collected and taken to the EVACUATION POINT. Own vehicles may be used for these purposes. You may continue to transport to off site. Ensure to stop at the Gate and give them a list of who was moved off site.
- RED CROSS shall decide on the condition of those in their care to transport themselves, or if they need site vehicle/ ambulance transport.
- INTOXICATED PARTICIPANTS should be escorted by friends or in their absence by those prepared to use strength and persuasion to get them off the site.
- BARRIO LEADS shall ensure their camp mates are all accounted for, especially within tents.
- PARENTS shall be responsible for their children.

EVACUATION TO TOWN

If the conditions require it, the Local Governmental Agencies could declare a state of emergency, which will mean an evacuation of all people on site to the nearest facilities in the towns of Sarinena and Castejon de Monegros. If this is necessary, please follow the indications of people in high visibility vests (and of the Fire Brigade of course!), don't try to get back to your tent to grab your belongings and don't be a hero! Don't become part of the problem!

RETURN TO SITE

Once the threat has been neutralised/ contained, and if Malfare and Site Personnel or if applicable officials from the municipality and elsewhere think that it's safe to return to the site, a team from the Nowhere organization and Emergency Services will visit the site and assess the conditions; if it's deemed safe, all participants will be allowed back on site, returning in an orderly fashion.

FIRE DRILL

If you come to Nowhere with an EE pass, you will have to participate in the fire drill. Please foliow all instructions on that important moment of time, because the legal permit of the event depends on it.

NO JOKE, we will have to do it the correct way.



LAW GENERAL CONDITIONS OF PARTICIPATION AND ACCESS TO NOWHERE 2019

The purchase of the ticket and/or entry to Nowhere (“the Event”) implies the acceptance and agreement of the following terms and conditions, as Participant:

1. DISCLAIMER

THE PARTICIPANT VOLUNTARILY ASSUMES THE RISK OF PROPERTY LOSS, SERIOUS INJURY OR DEATH BY ATTENDING THIS EVENT, AND ASSUMES AS WELL FULL RESPONSIBILITY AND LIABILITY FOR THEIR PARTICIPATION.

Art installations, theme camps (Barrios), vehicles, events and performances are not owned or operated by Nowhere (Europe) Ltd and/or Nowhere España (‘NOrg’) and therefore the Participant also assumes any and all risk of injury or loss associated with or arising from their operation or occurrence and release NOrg from any claim arising from this risk.

The Participant agrees to hold NOrg, its officers, directors, members, employees, volunteers, representatives, agents, contractors and subcontractors, and other participants, harmless from any damages, injuries, losses, liabilities and expenses relating to, resulting from or arising out of the participation in any programme, event, activity or service at the Event. The Participant also agrees that the present terms and conditions shall be construed broadly to provide a release and waiver to the maximum extent permissible under all applicable law.

2. REMEMBER THAT

The Participant agrees to read and abide by the present conditions, all the rules in the Survival Guide, principles of participation,

as well as to comply with local and national Spanish laws. All vehicles, including trucks, trailers and campers entering and exiting Nowhere.

Event site are subject to search by the Gate staff. The Participant must bring enough food, water, shelter and first aid to survive one week in a harsh desert environment. Commercial vending is prohibited, as are all firearms, solid fuels, fireworks, rockets and other explosives.

This is a LEAVE NO TRACE Event. You are asked to contribute at least one hour of site cleanup in addition to your own camp, before departure.

3. RIGHT OF ADMISSION

Children under 18 years of age must be accompanied by their mother, father or guardian. If a Participant brings a child to the event, then they agree on behalf of the child to the contractual terms and conditions and they are solely responsible for the child, holding NOrg harmless from any liability or damages, while at the Event.

Any conduct that is contrary to the Participant Code of Conduct and to the Law, will not only lead to expulsion from the event without possibility of re-entry, but will be notified to the competent authorities, NOrg declines any responsibility for these acts.

Entering the event without a ticket or

a valid wristband and/or helping other people to enter the event without a ticket or a valid wristband, and/or being found on the event premises without a ticket or a valid wristband will lead to immediate expulsion from the event and notification to legal authorities. Entry to the Event is a revocable license that may be revoked at any time for any reason in accordance to law.

4. EARLY TERMINATION OF THE EVENT

The amount of the ticket is non-refundable even if the Event is terminated early, due to harsh weather, acts of nature, governmental regulation or other conditions beyond NOrg’s control.

5. PRIVACY

To protect the rights to privacy and free expression of the Participant, use of images taken at Nowhere (other than for personal use) is strictly prohibited without the prior written consent of NOrg.

RELEASE OF IMAGE AND SOUND RIGHTS DURING NOWHERE 2019

Nowhere, celebrated during the summer of 2019 in the Monegros Desert, is a family and convivial event attended by thousands of people of all ages, religions, beliefs and ways of seeing life.

The personal image is protected in Spain by the Organic Law 1/1982 of May 5, Civil Protection of the Right to Honor, Personal and Family Intimacy and the Own Image. This Law is supported by the new European regulation on Data Protection and image dissemination.

Therefore, by accepting the terms and conditions of attendance to the event that are specified from the moment of purchase of the entry or allowed access to the press during the same, we indicate that any image, sound, video, text or system of capture of the same taken during the event will be assigned to the Organization.

This assignment occurs irrevocably and may not be invoked later in any case.

Also, any sale, rental, lease or assignment to third parties of these elements taken before, during or after the event is completely prohibited by the Organization in favor of maintaining privacy, the right to own image and the protection of minors attending. .

Any action that violates this clause will be prosecuted by the Organization and by the interested parties, resorting to as many civil, criminal and administrative instances as necessary.

The non-acceptance of this clause is cause for exclusion or immediate expulsion from the event without the right to reimbursement in case of violation of the same.

6. UPDATES

We may from time to time contact the Participant by email or post with news and information about Nowhere and related events. We may need to update the present terms and conditions from time to time.

The Event and entry, and the present conditions are subject to the applicable Spanish law. In case of dispute with NOrg, the Participants with express renounce to its own or applicable jurisdiction, accept to be bound by the Courts and Tribunals of the city of Barcelona. Moreover, in case of discrepancy on the translation of the present conditions, Spanish version shall prevail.

Be aware that, under Spanish law, the police can search your car with little suspicion. Remember to cooperate.

THAT'S ALL FOLKS!
SEE YOU IN THE DIRT!



No-credits: This guide is a cooperation of several tiny humans. As many communal effort things at Nowhere, we will not sign it. You can send an email at survivalguide@goingnowhere.org to contact us. If you aren't happy about some content, you can send an email at spam@goingnowhere.org